

URF - series

PCA COMPANY®

PISHTAZ CONTROL APADANA



Compact transmitters for non-contact level measurement, designed for industrial usage, Weather Resistant (IP68), MODBUS RTU Support, Noise Rejection, Auto Calibration, High Resolution, Automatic Temperature Compensation, Up to 10m Detection

Features

- ✓ High Measurement Resolution
- ✓ 16 Bit Resolution 4-20mA Analog Current Output
- ✓ Weather Resistant IP68
- ✓ Temperature Compensation
- ✓ Reject noise & High Acoustic Power Output
- ✓ Optimized Audio Signal Nondestructive
- ✓ Precise Narrow Beam
- ✓ Low power battery base systems
- ✓ Adjustable All Parameter With Software
- ✓ Industrial Sensor

URF Order & Model Number

URF-XX-X-XX-X

XX = Measurement range

- XX = 87 >> 30cm to 3m detection
- XX = 90 >> 30cm to 6m detection
- XX = 95 >> 50cm to 10m detection

X = Output resolution

- X = C >> 1 centimeter
- X = M >> 1 millimeter

XX = Input/Output

- XX = 00 >> Just support MODBUS RTU with interface RS 485
- XX = 01 >> MODBUS RTU & LOW – HI digital output
- XX = 10 >> MODBUS RTU & 4-20 mA current output
- XX = 11 >> MODBUS RTU & 4-20 mA current & LO – HI DO

X = Cable length

- X = 1 >> L = 5 meter
- X = 2 >> L = 10 meter
- X = 3 >> L = 15 meter
- X = 4 >> L = 20 meter
- X = 5 >> L = 25 meter
- X = 6 >> L = 30 meter

Beam Pattern

Characteristic response curve

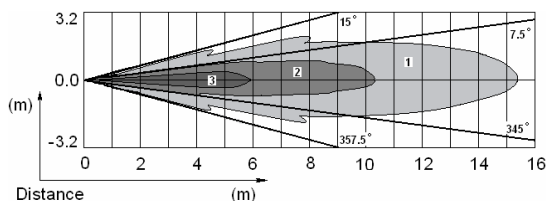

Curve 1: flat surface 150 mm x 150 mm
Curve 2: flat surface 80 mm x 80 mm

Technical data

General specifications

Range detection	Up to 10m
Measuring Scale	1mm/1cm
Block distance	50cm different at models
Standard target plate	different at models, flat 150 mm x 150 mm maximum
Transducer frequency	approx. 40 kHz
Reading cycle	200 ms

Electrical specifications

Operating voltage	12 ... 24 V DC, ripple 10 %SS
Standby current	3.8 mA without 4-20mA output
Run current	4.6 mA without 4-20mA output

Industrial protocol

MODBUS RTU	MODBUS RTU
Function code support	FC03 & FC04

Interface

Baud rate support	9600, 19200, 38400, 57600, 115200
Serial interface	Half duplex RS 485
Interface type	No parity, 8 data bits, 1 stop bit

Input/Output

Synchronization	Bi-directional RS485 serial
2 Open collectors	Hi & low digital output 12V to 24V voltage – max current 150mA don't short circuit
Current output	1 current output 4 ... 20 mA ≤ 500 Ohm
Accuracy	± 0.25% of reading ± 1mm

Run

With pin3 violet wire	By connect pin3 to pin1 sensor is run and no connect sensor is stop
With MODBUS protocol	With send true MODBUS serial data sensor is measurement range and answer to master

Ambient conditions

Ambient pressure	0.7 bar to 3 bar (10.15 PSI to 43.5 PSI)
Ambient temperature	-35 ... 75 °C (-31 ... 167 °F)
Storage temperature	-40 ... 85 °C (-40 ... 185 °F)

Mechanical specifications

Cable type	8 wire shield cable
Protection degree	IP68
Housing material	ABS
Transducer material	Aluminum
Total weight	260 g ±5gr without cable

Applications

Tank level measurement

Continuous, non-contact liquids, bulk materials pastes, sludge and powdery to coarse

Industrial distance measuring

Volume monitoring, Motion control, Systems fault, Height monitors, Auto sizing, Box dimensions, Automated pump station

Security

People detection

Weather station monitoring

URF-SERIES 8 Pin Out

Shielded cable

You should to connect shielded cable to the earth ground.

Pin 1 – (-V) - Blue

Sensor -V pin: DC return, and circuit common ground.

Pin 2 – (+V) - Red

Operate DC voltage on +12V to +24V.

Pin 3 – (RUN) - Violet

When this pin is connect to pin1 (-V), the sensor will continually measure and output the range data. If the pin is left unconnected, the sensor will stop ranging.

Note: Avoid of the connect pin3 to pin2.

Pin 4 – (+I) - Yellow

DC output 4-20mA current loop max RL 500Ω return to (-V). It is simple interface connect to all PLC's, Computer, etc, Data logger, RTU. The sensor measurement every cycle and send 16 bit resolution analog, for avoid sudden analog ripple of fault measurement user can be get average by device.

Pin 5 – (B) - Brown

Inverting Receiver Input B
RS-485 = 2-wire, half-duplex, differential, multi-drop communications standard for distances up to 4000ft.

Pin 6 – (A) - Green

No inverting Receiver Input A
RS-485 = 2-wire, half-duplex, differential, multi-drop communications standard for distances up to 4000ft.

Pin 7 – (L) - White

Digital output open collectors 150mA max current. The open collector switch enable after 4 times true read level more than Hi enable switch.

Pin 8 – (H) - Black

Digital output open collectors 150mA max current. The open collector switch enable after 4 times true read level less than Low enable switch.

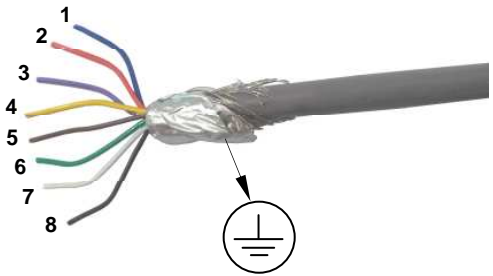

Notes

- The URF series has software to change and setup parameter so each sensor connected to PC before run for setup.
- Through two way can be run sensor and read measurement range on output pins (5/6) = serial RS485, pin (4) = 4-20mA analog and pins (7/8) digital low/high switch.
 - If pin3 is connected to -V (pin1), sensor starting measurement and make output, see in section software on after page.
 - With send true request MODBUS of master, sensor answer to request and make output, see in section software on after page.
- When installing sensors to devices with high noise must be use isolated filter in line
- Used 12V to 24V with min 500mA, industry power supply must be low noise for best operation
- The shielded cable is a great solution to use when running the sensors at a long distance or in an area with a lot of EMI and electrical noise, and is better the shielded cable connect to the earth ground.

URF-series wiring schematic

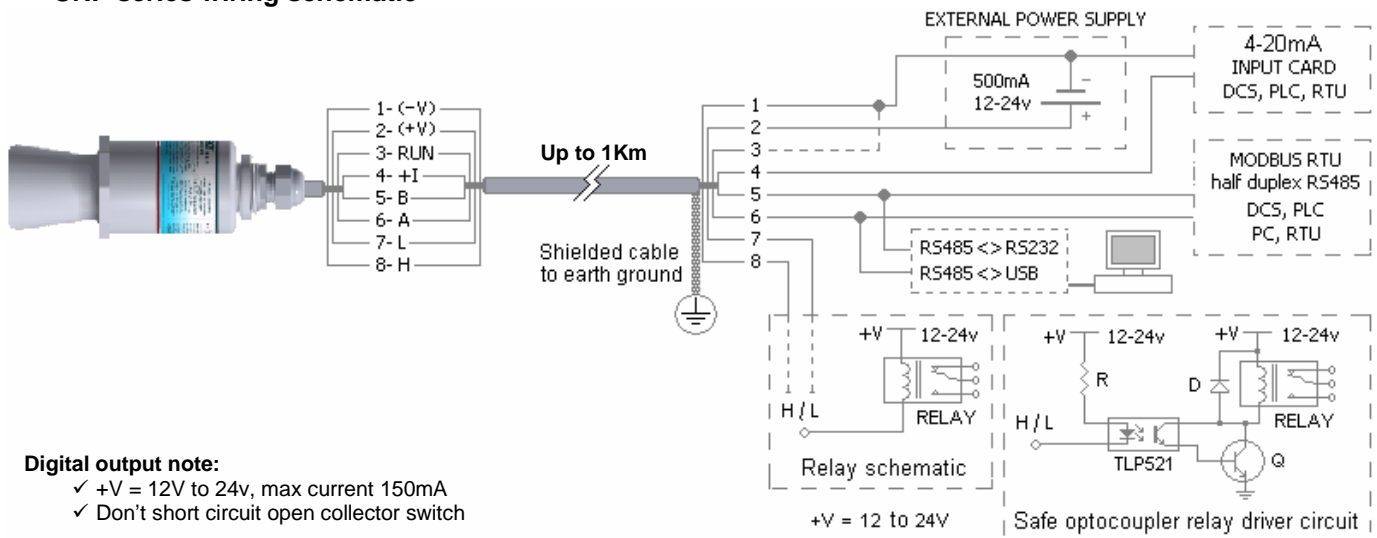

URF series program

User must be set the all parameters depend on sensor models type, for the first step, download last version of software from the website and setup on computer, then for communication to PC, You must to use RS485<->RS232 or RS485<->USB converter module and pin3 be must left unconnected then open the software, in first windows you should set com port, then if the communicate is true in new windows according to front photo view default Baud Rate, if Baud Rate box show NON item, then connect is false, in below work steps is described.

Note: if length cables more than 10 meter then shielded cable connect to earth ground and then reject noise for communicate.

1. you must press read then show default parameter, then sensor model and write button is active, be sure if resolution is mm write numbers with mm and if that is cm write numbers with cm.

Note: may be depend on sensor model some parameter is no active.

2. (Baud Rate):

If you would like to change baud rate you must select once items: 9600, 19200, 38400, 57600, 115200,

3. (Salve Address):

This box is for MODBUS RTU slave address, the default address is show. You must be set from 1 to 247 for change this item.

4. (Empty):

The default value empty is shown, you must enter maximum distance range depend on sensor models and measurement distance. This parameter is indicated by the letter E on photo

5. (Full):

The default value Full is shown, this parameter change the range measurement and output depend on that. This parameter is indicated by the letter F on photo

6. (Low DO):

This parameter show value low or alarm low switch, the switch is enabling after 4 time Tank Level measuring less than it.

7. (Hi DO)

This parameter show value high or alarm high switch, the switch is enabling after 4 time Tank Level measuring more than it.

8. Optimizing Gain Receiver (OGR):

This parameter optimize ultrasonic gain receiver for reject noise and easy installation. This parameter has three options that best value is setup in factory, if the value is low then noise is reduced and if the value is high than vice versa. This ability is causes increase sensor efficiency & quality.

9. Optimizing Measurement Beam (OMB):

This parameter optimize extent sound in ultrasonic for measurement beam and easy installation. This parameter has three options that best value is setup in factory, if the value is narrow then beam is little and if the value is wide than vice versa. This ability is causes increase sensor efficiency & quality.

Note: change this value of parameter affect sensor measurement range

10. After change all value parameters you must press write button until sensor setup complete.

11. At this time put the sensor in front of the wall or ceiling, and press Get Level button then measuring distance.

12. The measurement distance range is shown, which consists of:

13. (Tank Level):

This parameter show the amount of range tank usage, so this value = distance of sensor to target – Empty.

14. (mA):

This box show the amount of equivalent analog, depend of Tank level.

15. (Distance):

This box show the distance of sensor to target.

16. (C°):

These boxes show the air temperature.

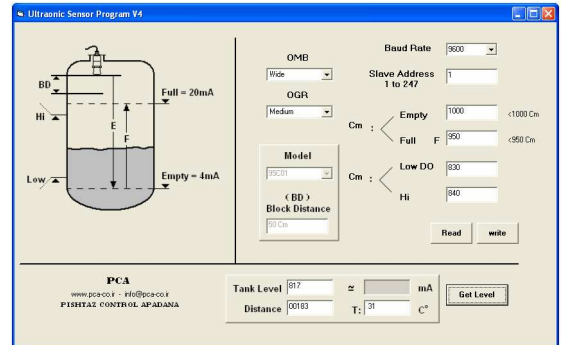

Run sensor ways:

With two ways can be run sensor and get output on (pin 5/6) RS485 serial, (pin4) 4-20mA analog, (pin 7/8) digital open collector switch

- Run trough as connect pin3 to pin1, then sensor manually measurement distance and out put is like below:
 - RS485 serial output:**
In this output you must be set hyper terminal on constant type (8 Data bits, No Parity, 1 Stop bits) and select true baud rate, and then you see measurement range on that to following format type:
Example: for sensor with mm resolution, **R02700 T 25** show, distance of sensor to target = 2700mm and air temp = +25°.
Example: for sensor with cm resolution, **R00270 T 25** show distance of sensor to target =270 cm and air temp = +25°.
Be sure capital R and T is constant, if temp < 0 then temp show like **T-25**.
 - 4-20 mA analog output:**
The output is amount of equivalent analog, depend of Tank level.
 - L switch output:**
The switch is enabling after 4 time Tank Level measuring less than value of Low DO.
 - H switch output:**
The switch is enabling after 4 time Tank Level measuring more than value of Hi DO.
- Run trough send true request MODBUS RTU of master in function FC03 or FC04 to sensor slave address, sensor answer to request and make analog & switch output like up, distance value is in 64Hex and air temp is in 65Hex address,

Note:

Before setup or run sensor and read rang trough MODBUS protocol you must disconnect pin3 to pin1.

MODBUS RTU communion protocol

RTU is most usable industrial MODBUS protocol, with RS485 interface can be connect up to 247 slaves into master device. In MODBUS RTU protocol communicate is according to request/answer, the one master request to unique slave and slave answer to master, for example in this method user can be connect 247 sensor to one bus and get range from them.

Supported Function Code FC03 & FC04

Read Holding Registers

You can see FC03 example & flowchart in front photo

Starting Address of 64 to 65 HEX

Reads internal registers containing
 2 byte of 64 HEX for Measurement range
 2 byte of 65 HEX for temperature to centigrade

Request

Function code	1 Byte	0x03
Starting Address	2 Bytes	0x0000 to 0xFFFF
Quantity of Register	2 Bytes	1 to 125 (0x7D)

Response

Function code	1 Byte	0x03
Byte count	1 Byte	2 x N'
Register value	N' x 2 Bytes	

N' = Quantity of Register

Error

Error code	1 Byte	0x83
Exception code	1 Byte	01 of 02 of 03 of 04

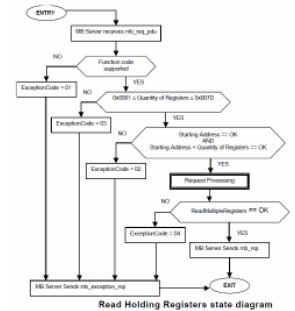

Factors Influences on finding the distance

An understanding of radiation patterns and the target's effect on echoes is essential to evaluating candidate sensors in terms of frequency variations, accuracy and Resolution, target range, effective beam angle, and the influence of ambient temperature variations on sensor performance. In URF series two parameter is effective on sensitivity and measurement beam diameter the following two parameters is OGR & OMB then user can be change value with free software. In the bellow table all measurement parameter by 6m sensor with change OGR and OMB is type. Test conditions are real in the room at temp 25c with wall surface target. Existence is two parameters a very positive effect in the install sensor at all places. It is noteworthy value of another sensor about correspondingly is decrease or increase for example 3m sensor is about half and 10m is about double.

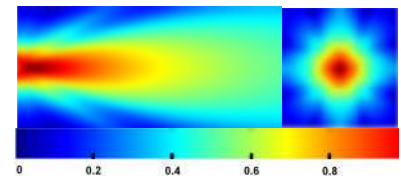

Maximum distance measurement with 6m model sensor at 25c temp	6.5m	6m	5.5m	5m	4.5m	4m	3.5m	3m	2.5m
OGR Adjusted	High	High	High	Medium	Medium	Medium	Low	Low	Low
OMB Adjusted	Wide	Widish	Narrow	Wide	Widish	Narrow	Wide	Widish	Narrow
Maximum of radius beam	25cm	22.5cm	20cm	20cm	17.5cm	15cm	15cm	12.5cm	10cm
(Block Distance)	40cm	35cm	30cm	42cm	37cm	32cm	44cm	39cm	34cm

URF series Benefits

- ✓ **Temperatures calibrate:**
The speed of sound in air at different temperature is variable, so for true measurement distance, at different air temp, should calibrate measure distance with speed of sound in air. The URF series sensor has internal industrial temp detection, then with unique design, the sensor with high speed and accuracy, can be measure speed of sound in air and calibrated distance with that.
- ✓ **Rejection noise:**
The URF series sensor is very good operate in place with external noise like, electromagnetic and radiation UV and sound noise with high dB, and this protect is for the best of design software, hardware and housing sensors.
- ✓ **Low current draw & wide voltage range:**
This sensors operated with low current draw < 4mA then this parameter is very effective in longevity battery usage, the URF support wide voltage range 12 to 24v for industrial usage.
- ✓ **Species serial, analog, switch output:**
These sensors have Species industrial output, for better and easy usage, these outputs can add or removed according to customer's favorite. Directional serial with interface RS485, support species baud rate, support MODBUS RTU protocol, industrial 4-20mA with 16bit resolution and two open collectors switch low/high are other's features.
- ✓ **Easy run & setup parameter with software:**
The sensor with has appropriate design, run and measure distance so easily, also all sensor parameters can change by the software.
- ✓ **Easy & low cost installing, low weight, small & resistant body:**
The sensors has narrow total beam angle that help to installing in all place, also low weight (260g) help to it, the material housing URF series is ABS, then it is very hard and resistant in erosions.
- ✓ **Weather resistant IP68:**
The URF series has IP68 protect that can install in more places.
- ✓ **Optimized Audio Signal Nondestructive, for install in Explosive areas:**
The sensors audio signal has optimized power & wave that can install in explosive areas, also do high protect in all parameters for sensors hardware for safe it against explosions.
- ✓ **High resolution, high Stability, high accuracy:**
Usage of the best design software and hardware in sensors help to high resolution, stability and accuracy of that.
- ✓ **URF series have Low price and warranty against other samples.**

URF Mechanical Dimensions

- A. 8 wire electrical shield cables
- B. Retainer nut PG21 thread (German pipe thread) maintenance, easy to install sensors in each local
- C. Cable Gland PG11 (German pipe thread) the standard cable gland for reject moisture and dust
- D. Surface thread PG21 (German pipe thread)
- E. Surface Thread PG36 (German pipe thread)
- F. Gasket O Ring 2mm height
- G. Nut Gear big Wrench
- H. Epoxy resin

Symbol	a	b	c	d	e	f	g	h	i	j
mm	6.5	14.4	43	27	52	7	53	47.6	29	5
260 grams total weight without cable										
ABS Material housing										
Aluminum piezoelectric material										

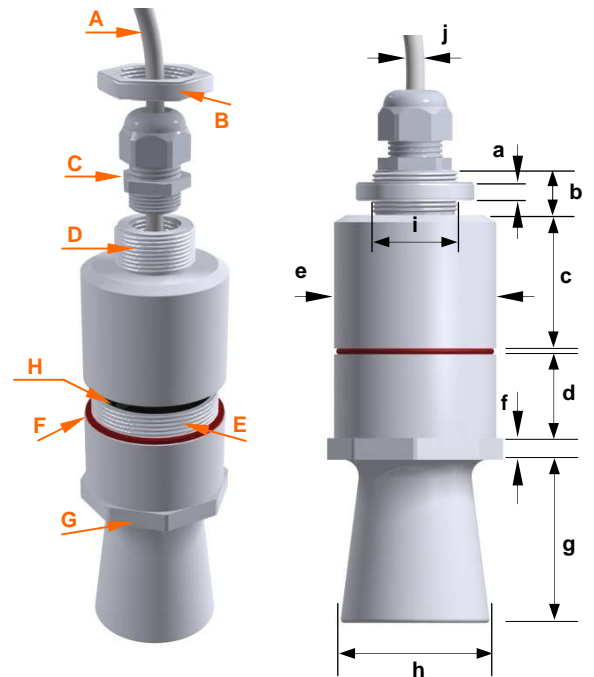

Note:

- Joints should be sealed until that no moisture enters in the sensor.
- Wire and cable should not under tension.
- Avoid installing in outdoor place with heavy winds.
- Avoid installing two parallel sensors beside together.
- For narrow place with protruding objects use of PVC pipe for transmission ultrasonic wave.
- The block distance is from zero to 20-60cm depending of models, that for installing, it must be consider.
- Strong waves or the foam on the measuring surface or dense vapor or gas makes the measurement impossible.
- Where there is no likelihood of interference.
- Mount on arm for pit or canal measurement.
- Keep within operating temperature and pressure ranges
- Avoid hit to the sensor when installing.
- Avoid mounting close to the inlet nozzle and interference.
- Avoid installing the sensor in the sun.
- Avoid mounting close to the center of the vessel.
- Mount the membrane parallel to the measured surface.
- Avoid dense vapor and gas in the vessel.
- Put cable in tube for rejection erosions.

You can see correct installation in the bellow photo; this is low cost & safe installation.



True & Wrong Installation

